



# FILTRINOV

## MX WITH SWIM COUNTER-CURRENT & BY-PASS

### MX 18 | CNO VT



Pools until 80m<sup>3</sup> max.  
Length max : 9m

### Equipment

- A** Removable cover with a mechanical safety (lock)
- B** Control box for filtration (automatic or manual) and lighting
- C** Buried part containing :
  - Filtration pump (18 m<sup>3</sup>/h)
  - **By pass system** in order to derivate the water flow until a heat pump for example.
  - **Swim counter-current** done by a 2nd pump, similar than the filtration one, the both are activate by a pneumatic switch.
- D** Double filtration cartridges + basket collecting leaves
- E** Balneotherapy (Air flow rate adjustment for massage functions)
- F** Skimmers, two openings for water suction
- G** Directional heavy flow rate
- H** LED light + remote control > Color in option

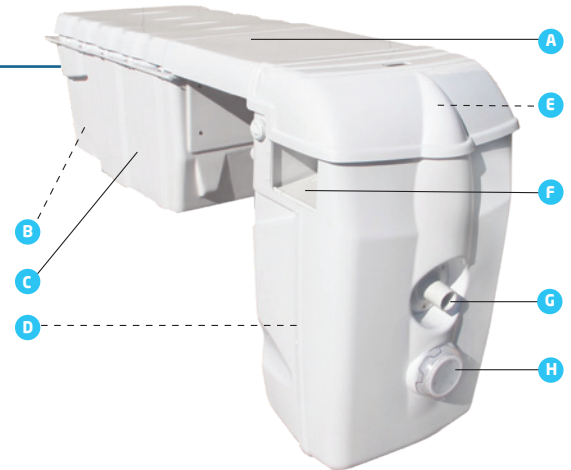

### General diagramm

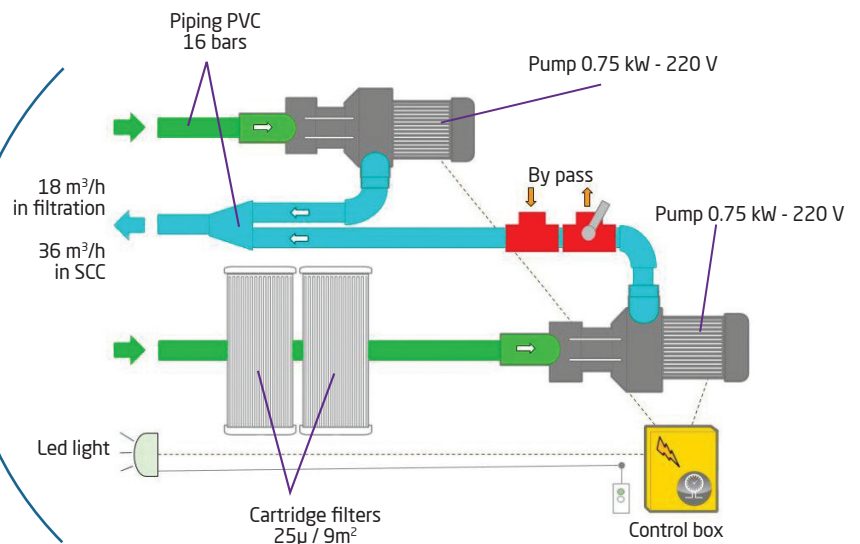

### Side plan of MX

